

Owner's Manual

Model PH-100

Headphone Amplifier / Distributor

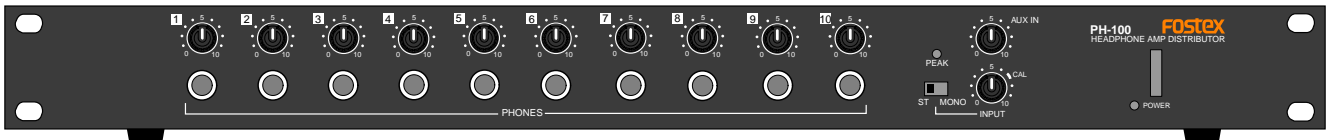

Introduction

Thank you very much for purchasing the Fostex PH-100 headphone amplifier/distributor. The PH-100 can distribute the input signal accepted by any of three pairs of stereo input connectors to 10 headphones whose level can be adjusted independently. It also provides the 10-input, 10-output matrix box function which allows independent feed for each headphone. The PH-100 is equipped with two stereo pairs of balanced inputs (+4 dBu XLR-3-31 connectors and -10 dBV phone jacks), as well as a stereo pair of unbalanced inputs (-10 dBV RCA pin jacks). It also provides the AUX IN jacks which are useful when using the PH-100 as a cue box.

In addition, you can cascade PH-100s, making more than 10 persons possible to monitor the same stereo source.

Please read through this manual before using, and always keep it nearby.

<Contents>

Safety Instructions	2
Notes on Operation	3
Names and Functions	
Front panel section	3
Rear panel section	4
Application Examples	
Example - 1: Using the PH-100 as a cue box	5
Example - 2: Using an individual talkback monitor facility	5
Example - 3: Cascading PH-100	6
Main Specification	7
Block diagram	7

Fostex®

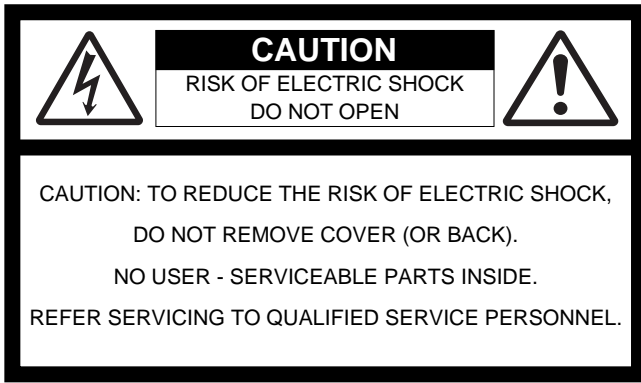

"WARNING"

"TO REDUCE THE RISK OF FIRE OR ELECTRIC SHOCK, DO NOT EXPOSE THIS APPLIANCE TO RAIN OR MOISTURE."

SAFETY INSTRUCTIONS

1. Read Instructions - All the safety and operating instructions should be read before the appliance is operated.
2. Retain Instructions - The safety and operating instructions should be retained for future reference.
3. Heed Warnings - All warnings on the appliance and in the operating instructions should be adhered to.
4. Follow Instructions - All operating and use instructions should be followed.
5. Water and Moisture - The appliance should not be used near water - for example, near a bathtub, washbowl, kitchen sink, laundry tub, in a wet basement, or near a swimming pool, and the like.
6. Carts and Stands - The appliance should be used only with a cart or stand that is recommended by the manufacturer.



An appliance and cart combination should be moved with care. Quick stops, excessive force, and uneven surfaces may cause the appliance and cart combination to overturn.

7. Wall or Ceiling Mounting - The appliance should be mounted to a wall or ceiling only as recommended by the manufacturer.
8. Ventilation - The appliance should be situated so that its location or position does not interfere with its proper ventilation. For example, the appliance should not be situated on a bed, sofa, rug, or similar surface that may block the ventilation openings; or, placed in a built-in installation, such as a bookcase or cabinet that may impede the flow of air through the ventilation openings.
9. Heat - The appliance should be situated away from heat sources such as radiators, heat registers, stoves, or other appliances (including amplifiers) that produce heat.

CAUTION:

TO PREVENT ELECTRIC SHOCK, MATCH WIDE BLADE OF PLUG TO WIDE SLOT, FULLY INSERT.

ATTENTION:

POUR ÉVITER LES CHOCS ÉLECTRIQUES, INTRODUIRE LA LAME LA PLUS LARGE DE LA FICHE DANS LA BORNE CORRESPONDANTE DE LA PRISE ET POUSSER JUSQU' AU FOND.



The lightning flash with arrowhead symbol, within an equilateral triangle, is intended to alert the user to the presence of uninsulated "dangerous voltage" within the product's enclosure that may be of sufficient magnitude to constitute a risk of electric shock to persons.



The exclamation point within an equilateral triangle is intended to alert the user to the presence of important operating and maintenance (servicing) instructions in the literature accompanying the appliance.

10. Power Sources - The appliance should be connected to a power supply only of the type described in the operating instructions or as marked on the appliance.
11. Grounding or Polarization - The precautions that should be taken so that the grounding or polarization means of an appliance is not defeated.
12. Power Cord Protection - Power supply cords should be routed so that they are not likely to be walked on or pinched by items placed upon or against them, paying particular attention to cords at plugs, convenience receptacles, and the point where they exit from the appliance.
13. Cleaning - The appliance should be cleaned only as recommended by the manufacturer.
14. Nonuse Periods - The power cord of the appliance should be unplugged from the outlet when left unused for a long period of time.
15. Object and Liquid Entry - Care should be taken so that objects do not fall and liquids are not spilled into the enclosure through openings.
16. Damage Requiring Service - The appliance should be serviced by qualified service personnel when:
 - A. The power supply cord or the plug has been damaged; or
 - B. Objects have fallen, or liquid has been spilled into the appliance; or
 - C. The appliance has been exposed to rain; or
 - D. The appliance does not appear to operate normally or exhibits a marked change in performance; or
 - E. The appliance has been dropped, or the enclosure damaged.
17. Servicing - The user should not attempt to service the appliance beyond that described in the operating instructions. All other servicing should be referred to qualified service personnel.
18. The appliance should be situated away from drops of water or spray of water.
19. Objects containing liquid such as vase must not be put on the appliance.
20. The appliance is not completely isolated from the power supply even if the power switch is at off position.

Notes on Operation

- **Do not use headphones for long hours at high sound levels.**
If the headphones is used under such condition, it could injure your hearing. Also, be careful not to rapidly raise the output control when using the headphone. Please use good sense to protect your hearing.
- **Switch off power when connecting external equipment to PH-100.**
Always switch off power to the PH-100 when connecting external equipment to it.
- **Retard the sound volume control when the headphone plug is connected or disconnected from the jack.**
Always turn down the sound volume control before the headphone is plugged or unplugged while the volume control is set too high, it could create noise and have hurt your ears.
- **Turn down all sound volume controls before switch on power.**
Be sure to fully turn off all sound volume controls when switching on/off power to the PH-100.

Names and Functions

Front Panel section

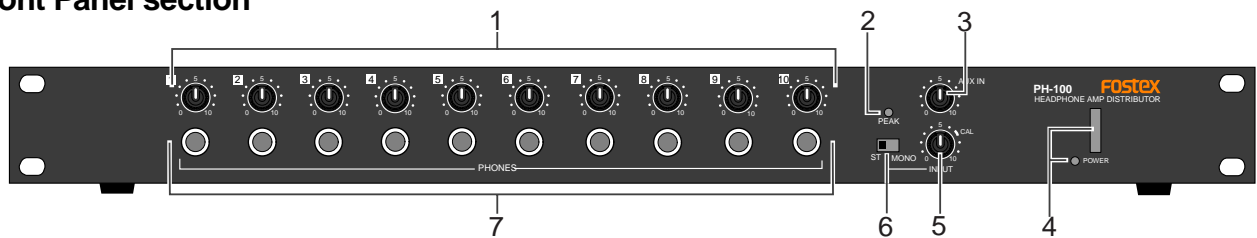

1. **[PHONES] level controls [1 through 10]**
Each control adjusts the output level of the corresponding [PHONES] jack (1 through 10) on the front or rear panel.
2. **[PEAK] indicator**
Represents overload of the input signal. If the indicator frequently lights up, turn down the [INPUT] and / or [AUX IN] level controls so that the indicator does not light up.
3. **[AUX IN] level control**
Adjusts the input level of a stereo signal from the [AUX IN] jacks on the rear panel. The signal adjusted by this control is mixed with the stereo signal from the [INPUT] jacks which is level-controlled by the [INPUT] level control, and fed to both the [PHONES] and [CASCADE OUT] jacks.
4. **[POWER] switch/indicator**
The switch turns on or off the power. The indicator lights up when the power is on. When turn on or off the power, set the level controls of the PH-100 and connected device(s) to the minimum positions.
5. **[INPUT] level control**
Controls the input level of the [INPUT] jacks (balanced or unbalanced) on the rear panel.

6. **[INPUT (ST, MONO)] select switch**
Selects whether monitoring a signal from the [INPUT] jacks (balanced or unbalanced) in stereo or mono.

ST	The input signal is fed to the [PHONES] and [CASCADE OUT] jacks in stereo.
MONO	The input signal is fed to the [PHONES] and [CASCADE OUT] jacks in mono (L+R).

7. **[PHONES] jacks (1 through 10)**
Connect headphones. There are also headphone jacks on the rear panel so you can use whichever you like.

<Note>

Each headphone jack on the front panel take priority to the corresponding (same number's) headphone jack on the rear panel.
You cannot use both front and rear jacks with the same number simultaneously. If you connect headphones to both front and rear jacks with the same number, you can only use the headphones connected to the front jack.



<Note>
At the CAL position, you can get the nominal input level (+4 dBu or -10 dBV). CAL position shows the nominal position."

Rear Panel section

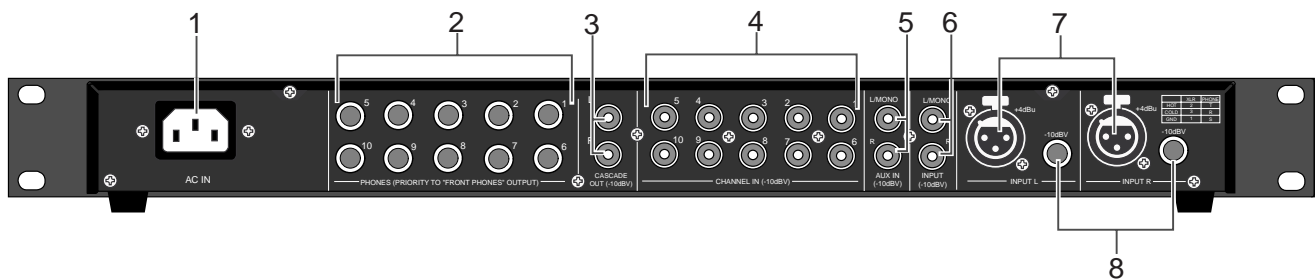

1. [AC IN] connector

Connects the supplied power cord.

2. [PHONES] jacks (1 through 10)

Connect headphones. There are also headphone jacks on the front panel so you can use whichever you like.

<Note>
 Each headphone jack on the front panel take priority to the corresponding (same number's) headphone jack on the rear panel.
 You cannot use both front and rear jacks with the same number simultaneously. If you connect headphones to both front and rear jacks with the same number, you can only use the headphones connected to the front jack.

3. [CASCADE OUT] jacks (L, R) (RCA: -10dBV)

To cascade two PH-100s, connect between the cascade jacks of the first unit and the unbalanced [INPUT] jacks of the second unit. See page 6 for details about cascade connection.

4. [CHANNEL IN] jacks (1 through 10) (RCA: -10dBV)

The signal from each input jack is directly sent to the corresponding headphone output. i.e. The signal from [CHANNEL IN 5] is directly output from [PHONES 5].

5. [AUX IN] jacks (L/MONO, R) (RCA: -10dBV)

Connect to -10 dBV unbalanced output connectors of an external device. A stereo signal from these input jacks is sent the [PHONES] jacks (1 through 10) on front and rear panel. If you connect a plug only to the L/MONO jack, the same signal is sent to both L and R channels. You can control the signal level using the [AUX IN] control on the front panel.

6. [INPUT (-10dBV)] jacks (L/MONO, R) (RCA: -10dBV)

Connect to -10 dBV unbalanced output connectors of an external device. A stereo signal from these jacks is sent the [PHONES] jacks (1 through 10) on front and rear panel. If you connect a plug only to the "L/MONO" jack, the same signal is sent to both L and R channels.

You can control the signal level using the [INPUT] control on the front panel.

To cascade two PH-100s, connect between the [CASCADE OUT] jacks of the first unit and the unbalanced [INPUT] jacks of the second unit. See page 6 for details about cascade connection.

7. [INPUT (+4dBu)] connector (L, R) (XLR-3-31 type: +4dBu)

Connect to +4 dBu balanced output connectors of an external device. A stereo signal from these balanced connectors are sent [PHONES] jacks (1 through 10) on front and rear panel. You can control the signal level using the [INPUT] control on the front panel.

The pin assignment of the XLR connector

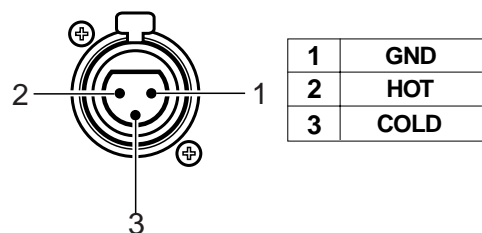

8. [INPUT (-10dBV)] jacks (L, R) (PHONE: -10dBV)

Connect to -10 dBV balanced output connectors of an external device. A stereo signal from these balanced connectors are sent [PHONES] jacks (1 through 10) on front and rear panel. You can control the signal levels using the [INPUT] control on the front panel.

The pin assignment of the phone plug

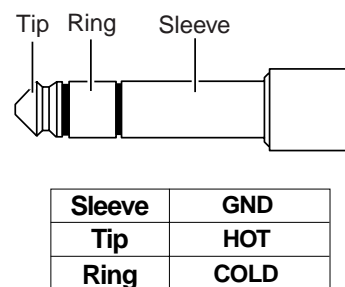

Application Examples

<Example - 1: Using the PH-100 as a cue box >

The following figure shows the example of using PH-100s as cue boxes for recording. Each PH-100 is installed in each booth of a recording studio. Musicians in each booth can monitor the sound with the desired balance between signals from the [INPUT] and [AUX IN] jacks by adjusting the [INPUT] and [AUX IN] controls on the front panel.

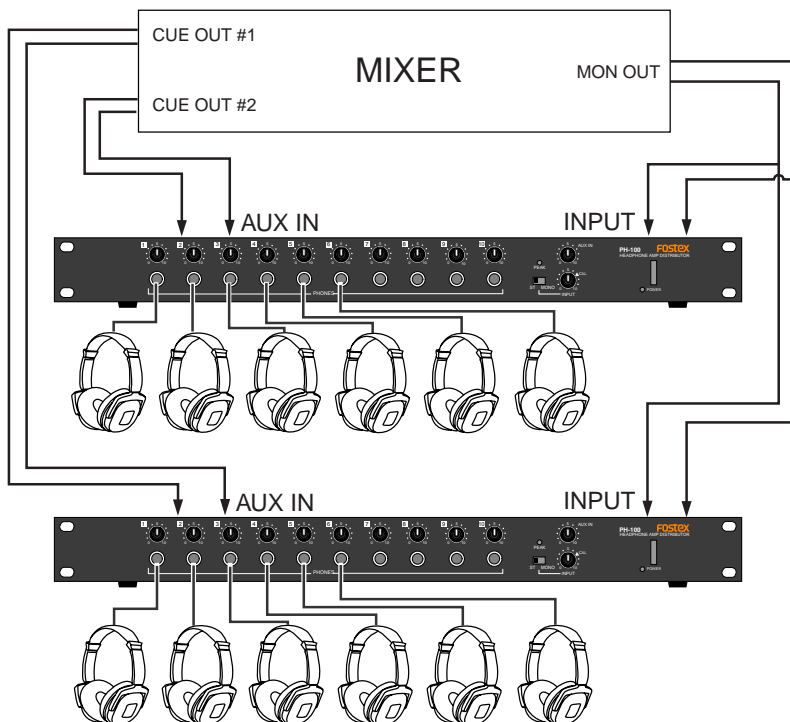

<Example - 2: Using an individual talkback monitor facility>

The following figure shows the example of using an individual talkback monitor facility of the PH-100. By connecting each [CHANNEL IN] jack to an individual cue output of the mixing console which can send a talkback signal, you can send talkback to an individual musician.

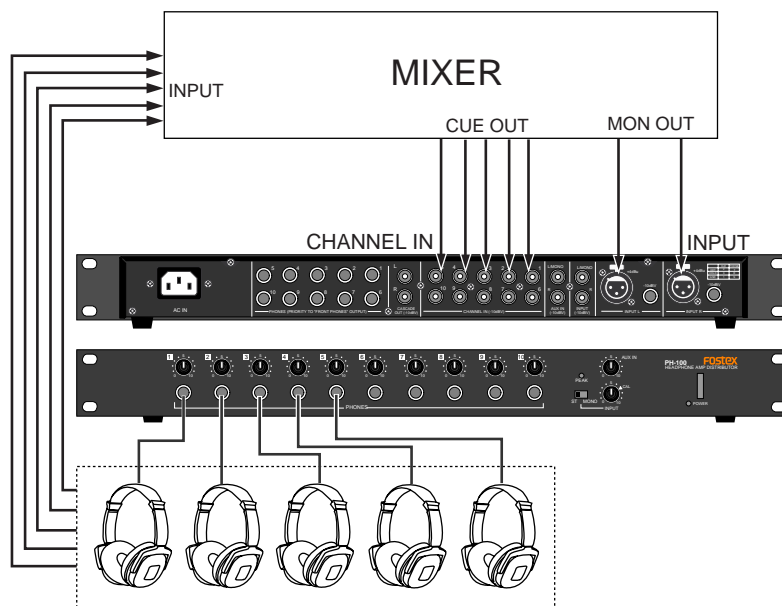

<Example -3: Cascading PH-100>

The following figure shows the example of cascading three PH-100s, allowing 30 persons to monitor the same stereo source. You can cascade up to 10 PH-100s (allowing 100 persons to monitor). Note that we do not guarantee the function when cascading more than ten PH-100s.

<Notes for cascading>

- To cascade PH-100s, connect between the **[CASCADE OUT]** jacks (L, R) of the first unit and the unbalanced **[INPUT (-10 dBV)]** jacks (L, R) of the second unit. In the same way, connect between the second and third units.
- By setting the **[INPUT]** control of the second and third units to the "CAL" position, you can control all headphone output levels using the **[INPUT]** control of the first unit.

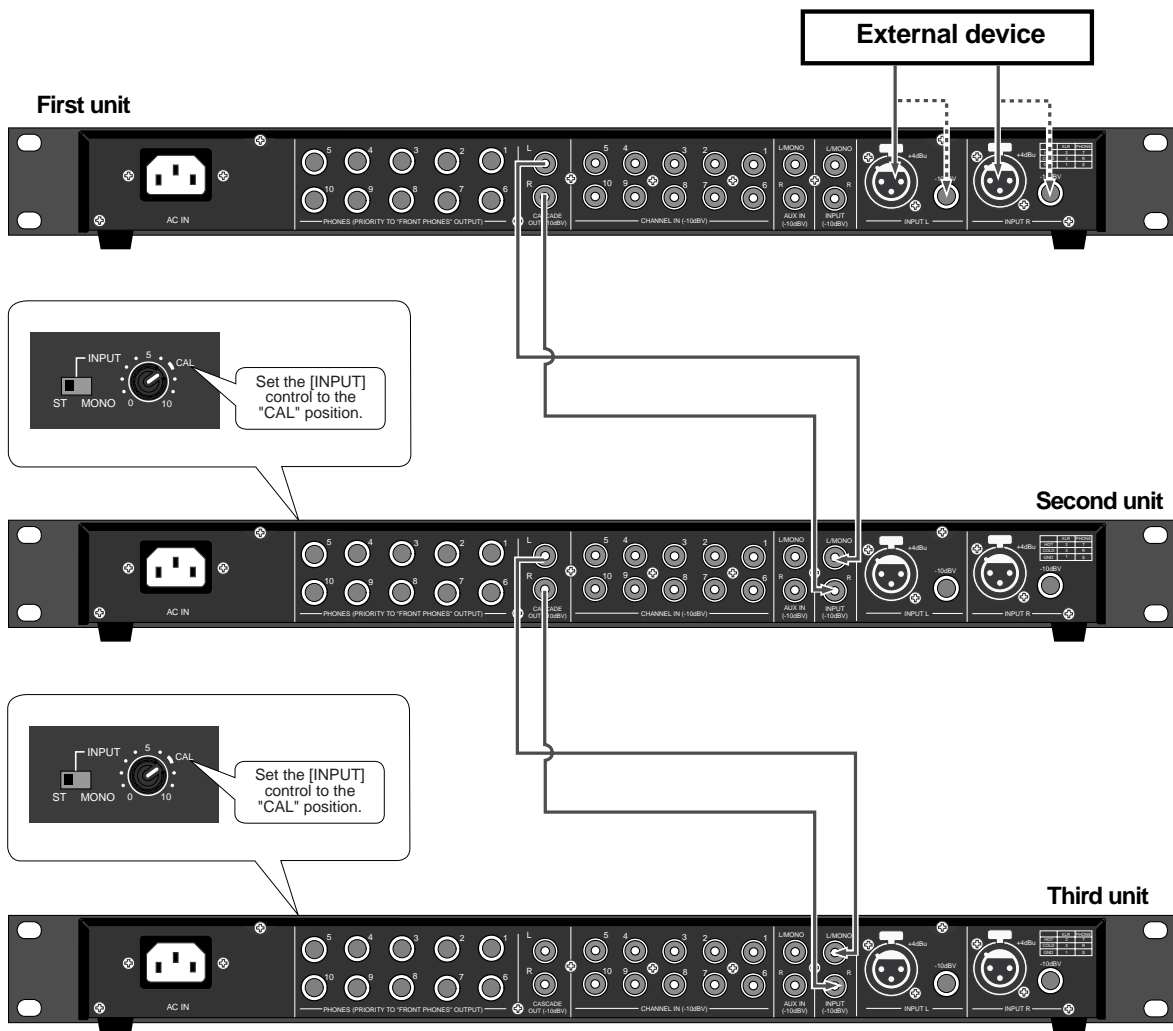
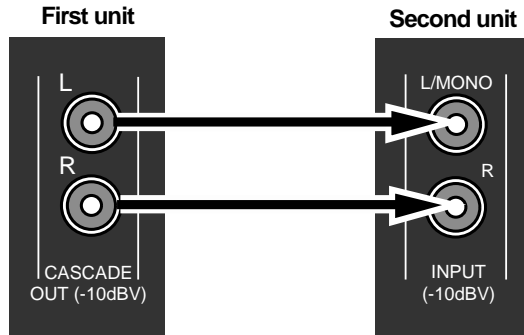

Main Specification

<INPUT>

INPUT (L, R) (Balanced)

- Connector : XLR-3-31 type (x 2)
: PHONE (x 2)
- Standard input level : +4dBu (XLR-3-31 type)
: -10dBV (PHONE)
- Input Impedance : 10kΩ or more

INPUT (L/MONO, R) (Unbalanced)

- Connector : RCA pin (x 2)
- Standard input level : -10dBV
- Input Impedance : 10kΩ or more

AUX IN (L/MONO, R) (Unbalanced)

- Connector : RCA pin (x 2)
- Standard input level : -10dBV
- Input Impedance : 10kΩ or more

CHANNEL IN (1~10) (Unbalanced)

- Connector : RCA pin (x 10)
- Standard input level : -10dBV
- Input Impedance : 10kΩ or more

<OUTPUT>

PHONES OUT (1~10)

Available on both the front and rear panels (the front jacks take priority.)

- Connector : PHONE (x 20)
- Maximum Output level : 500mW
- Load impedance : 8 ~ 32Ω
- Frequency Response : 30Hz ~ 20kHz +/-1dB
- Noise : -65dBV or less
- Distortion : 0.3% or less

CASCADE OUT (L, R)

- Connector : RCA pin (x 2)
- Output level : -10dBV
- Frequency Response : 30Hz ~ 20kHz +/-1dB
- Noise : -80dBV or less
- Distortion : 0.1% or less

<GENERAL>

- Dimensions : 482 (W) x 49 (H) x 267 (D)
- Weight : Approx. 4kg
- Power supply : 120VAC 60Hz
: 230V ~ 50/60Hz
- Power consumption : Approx. 18W

* Specifications and appearance are subject to change without notice for product improvement.

Block diagram

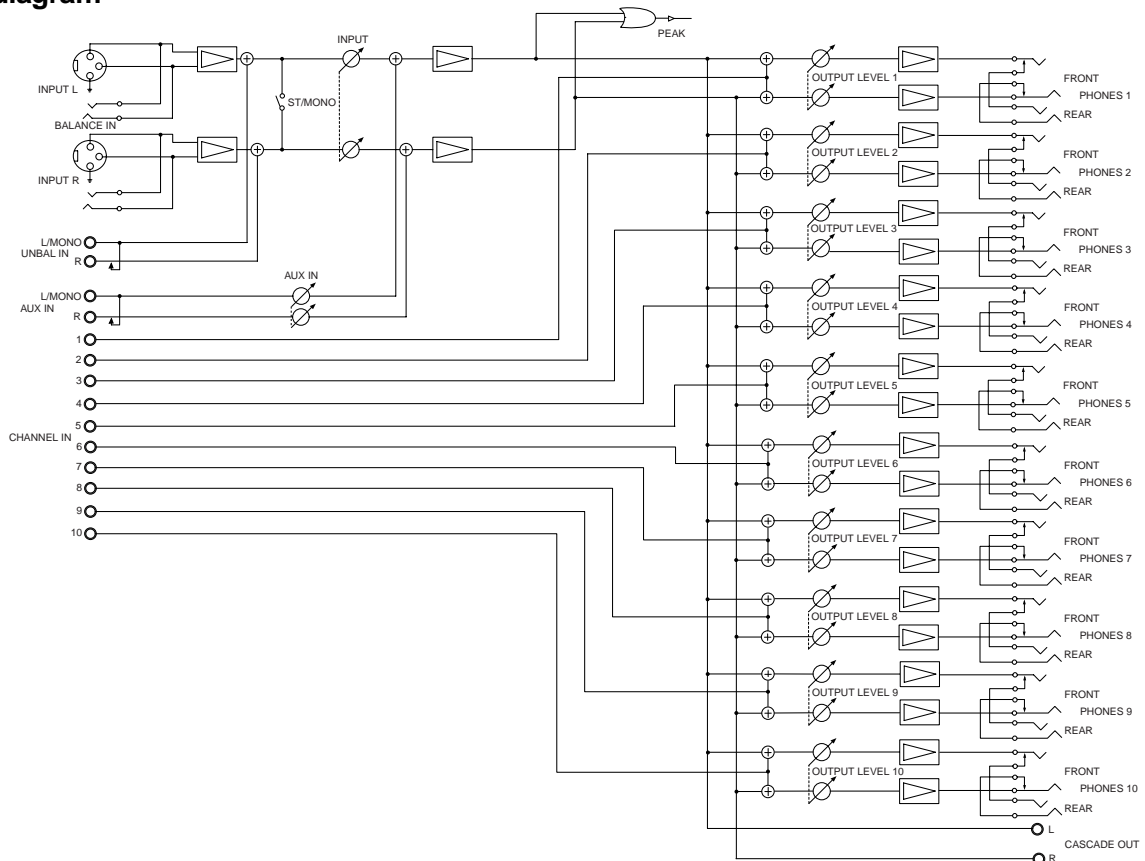

Declaration of EC Directive

This equipment is compatible with the EMC Directive (89/336/EEC) - Directive on approximation of member nation's ordinance concerning the electromagnetic compatibility and with the Low Voltage Directive (73/23/EEC) - Directive on approximation of member nation's ordinance concerning electric equipment designed to be used within the specified voltage range.

The Affect of Immunity on This Equipment

The affect of the European Specification EN50082-1 (coexistence of electromagnetic waves - common immunity specification) on this equipment are as shown below.

In the electrical fast transient/burst requirements, surge, conducted disturbances by radio-frequency fields, power frequency magnetic field, radiate electromagnetic field requirements and static electricity discharging environment, this could be affected by generation of noise in some cases.

FOSTEX DISTRIBUTORS LIST IN EUROPE

* Including non-EU countries (as of June, 2002)

<AUSTRIA>

NAME: ATEC Audio-u. Videogeraete VertriebsgesmbH.
ADD: Im Winkel 5, A-2325 Velm, Austria
TEL: (+43) 2234-74004, FAX: (+43) 2234-74074

<BELGIUM>

NAME: EML Sound Industries NV
ADD: Bijvenestraat 1A, B3500 Hasselt, Belgium
TEL: (+32) 11-232355, FAX: (+32) 11-232172

<DENMARK>

NAME: SC Sound ApS
ADD: Malervej 2, DK-2630 Taastrup, Denmark
TEL: (+45) 4399-8877, FAX: (+45) 4399-8077

<FINLAND>

NAME: Noretron Oy Audio
ADD: P. O. Box 22, FIN-02631 Espoo, Finland
TEL: (+358) 9-5259330, FAX: (+358) 9-52593352

<FRANCE>

NAME: Guillard Musiques
ADD: ZAC de Follieuses, B. P. 609, Les Echets, 01706 Miribel, France
TEL: (+33) 472 26 27 00, FAX: (+33) 472 26 27 01

<GERMANY>

NAME: Studiosound & Music GmbH
ADD: Industriestrasse 20, D-35041 Marburg, F. R. Germany
TEL: (+49) 6421-92510, FAX: (+49) 6421-925119

<GREECE>

NAME: Bon Studio S. A.
ADD: 6 Zaimi Street, Exarchia, 106.83 Athens, Greece
TEL: (+30) 1-3809605-8, 3302059, FAX: (+30) 1-3845755

<ICELAND>

NAME: I. D. elrf. electronic Ltd.
ADD: ARMULA 38 108 REYKJAVIK, ICELAND
TEL: (+354) 588 5010, FAX: (+354) 588 5011

<ITALY>

NAME: Proel S. p. A.
ADD: Zona Alla Ruenia, 37/43 64027 - Sant'Omero (Teramo), Italy
TEL: (+39) 0861-81241, FAX: (+39) 0861-887862

<THE NETHERLANDS>

NAME: IEMKE ROOS AUDIO B. V.
ADD: Kuiperbergweg 20, 1101 AG Amsterdam, The Netherlands
TEL: (+31) 20-697-2121, FAX: (+31) 20-697-4201

<NORWAY>

NAME: Siv. Ing. Benum A/S
ADD: P. O. Box 145 Vinderen, 0319 Oslo 3, Norway
TEL: (+47) 22-139900, FAX: (+47) 22-148259

<PORTUGAL>

NAME: Caius - Tecnologias Audio e Musica, Lda.
ADD: Rua de Santa Catarina, 131 4000 Porto, Portugal
TEL: (+351) 2-2086009/2001394,
FAX: (+351) 2-2054760/2087488

<SPAIN>

NAME: Multitracker, S. A.
ADD: C/Garcilaso No.9, Madrid 28010, Spain
TEL: (+34) 91-4470700, 91-4470898, FAX: (+34) 91-5930716

<SWEDEN>

NAME: TTS Scandinavia AB
ADD: Kavallerivagen 24, 172 48 Sundbyberg, Sweden
TEL: (+46) 8-59798000, FAX: (+46) 8-59798001

<SWITZERLAND>

NAME: Audio Bauer Pro AG
ADD: Bernerstrasse-Nord 182, CH-8064 Zurich, Switzerland
TEL: (+41) 1-4323230, FAX: (+41) 1-4326558

<UK>

NAME: SCV London
ADD: 40 Chigwell Lane, Oakwood Hill Industrial Estate, Loughton, Essex IG10 3NY U. K.
TEL: (+44) 020-8418-0778, FAX: (+44) 020-8418-0624