

# W400AII

## Recommended Bass Reflex Type Enclosure

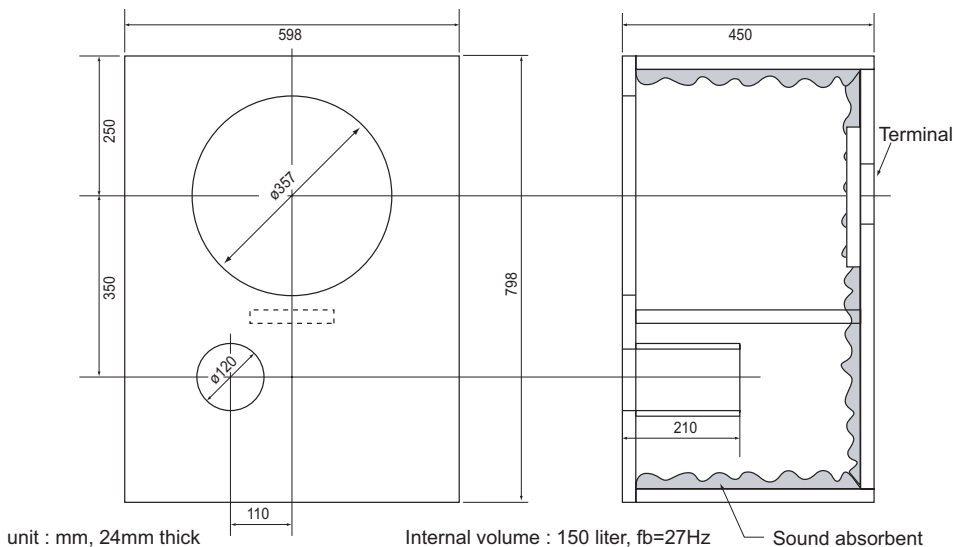

### W400AII + D1400 + H300 + T500A 3-way system

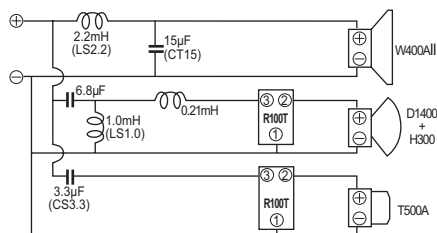

This is an example for 3-way system consists in W400AII, D1400 1" horn driver with H300 radial horn and T500A super tweeter. Its crossover frequencies are 800Hz and 6kHz. Enclosure (above fig.) is bass reflex type with 150 liters internal volume.

### W400AII + D1400 + H300 + T500A 3-way system

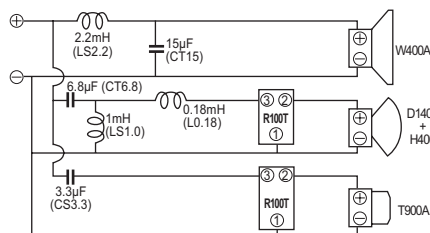

This is an another 3-way example switching the horn to H400 and super tweeter to T900A. Network's basic design is the same but crossover frequency between super tweeter and midrange is changed to 7kHz.

## Recommended Bass Reflex Type Enclosure

